

MULTI-MACHINE SYSTEM

FOR ARTISAN GELATO

du series



PASTMATIC



TINOX



GELMATIC



Pastmatic & Tinox

The base for large volume production



Pastmatic 60



Pastmatic 2x60

pastmatic®

Pastmatic is the technology which provides **pasteurization, coolin and ageing process** in one machine only taking up **very little space**.

2 models available: **Pastmatic 60** to pasteurize up to 60lt of mixture and **Pastmatic 2x60** equipped with 2 independent elliptical tanks for the production up to 120lt of gelato base. Both of them automatically run "high temperature" and "low temperature" pateurization cycles.

By Duo series, Pastmatic is completely updated:

▪ patented elliptical tanks of the new generation

For a perfect thermal exchange. The elliptical tank -if compared to other shapes- offers the advantage to **make the mixture smoothly run along** its walls (without beating) granting no standstill during stirring process and avoiding lumps making. It allows moreover to **reduce spaces** but to keep the same capacity of a round-shaped tank.



▪ new tank heating system

Designed for a careful heating management which is essential for **keeping the organoleptic properties**, the quality and the taste of food without alteration. The heating system radiates heat and makes mixture absorb it in a **smooth and not aggressive way**. Etched foil heating elements **ensure no thermal inertia** -which, instead, occurs in bain-marie heating systems- and **avoid the most delicate ingredients to burn**. Moreover, the new system is Duo: heating and cooling...

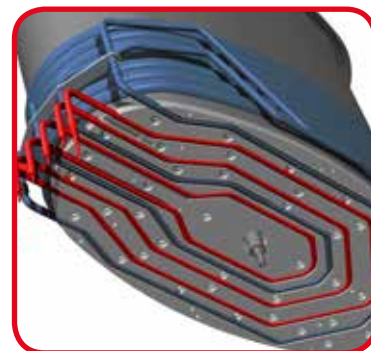

▪ smart tank cooling system

Tank is equipped with a smart and quick cooling system on both its bottom -**side which keeps longer in contact with the mixture**- and its side walls to **avoid the "igloo" effect**. "Igloo" effect occurs when some moisture coming from the external environment gathers on the walls of the tank, turns into ice and then melts affecting the quality of the mixture. Pastmatic ensures a gentle and **high quality cooling of the mixture even for low quantity of product**.

The **new evaporator** for the cooling process grants the same performance halving however the power installed.

▪ new stirrer-pump with high mixing performances

Also the new stirrer is covered by a patent: the device has now **increased of a 20% mixing and aspiration performances**. Stirrer works as a real pump thought which the mixture is sucked in and then strongly rubbed on the bottom of the tank to turn solids in liquids thanks to an effective heat exchange getting a smooth and homegeneous base. Stirrer can be removed from the top to **prevent unhygienic and difficult-to-clean deposits on the bottom of the tank**.



▪ quick and reliable cleaning process

Hygiene is essential in food processing and it's a quite critical issue as it require time and resources. Pastmatic has been designed to make this process be as easy and smooth as possibile and will allow:

- **QUICK cleaning**: in a short time user can clean, disassemble and re-assemble the **few components** which are involved during pasteurization process (tank, stirrer and tap)





- **EASY cleaning:** all the components to be cleaned are **visible and immediatly identifiable**, no hidden or difficult-to-reach parts.
- **DEFINITE cleaning:** once the few involved components are cleaned, the user is certain that the machine is sanitized for the next production cycle.

▪ **new electronic board "Duo series"**

A powerful machine is nothing without control. Thanks to the **new digital electronic board** and to the new generation probes, Pastmatic automatically and accurately controls mixing speed, temperatures and heating times, cooking and cooling process granting the mixture not to burn or to freeze during the preservation process. Everything always under control and easy to use thanks to the pre-set and free?production programs.



FEATURES

- Many operation cycles (high temperature pasteurization, low temperature pasteurization, stirring, cooling and refrigerated preservation).
- Electronic control of the pasteurization cycles.
- Anti-drop tap which totally goes inside the tank to grant the best hygiene preventing mixture leftover in the extraction channel.

ADVANTAGES

- Easy to clean
- More homogeneous mixture
- Stirrer speed can be changed anytime
- Little space required



PASTMATIC + TRITTICO

Supported by Trittico, Pastmatic becomes a precious ally able to produce up to 120lt of dedicated base (white, yellow, dark...). User can so decide to produce 60lt of cream base to quickly produce fiordilatte, stracciatella and variegated flavours to immediately fill your showcase up.



Tinox mod. 60

tinox

Tinox is the ageing vat which offers the same ergonomics and the reduced dimesions as Pastmatic. It allows to constantly keep mixture at 4 °C before starting batch freezing process. Tinox is an efficient cooler as well to cool down mixture from 85°C to 4°C and keep it at that temperature, allowing, in this way, to immediately empty the pasteurizer and to enable it starting a new heating cycle.

FEATURES

- Electronic control of the production cycle
- Elliptical tank
- Anti-drop tap easy to maintain

ADVANTAGES

- Easy to clean
- Energy saving
- More homogeneous mixture
- Water supply system for cleaning process



Tinox mod. 2x60



Startronic Premium

gelmatic®

Batch freezer Gelmatic Startronic Premium is the result of 50 years' experience of Bravo specialized R&D on combined machines.

The technology and the strong cold power developed for Trittico is also used for batch freezers, making Gelmatic unique and inimitable: a guarantee of quality that only Bravo can assure thanks to the numerous patents that make up the historical and technological heritage of the company.

▪ Cooling system

Patented refrigeration system formed by monobloc cylinder provided with multi-points and multi-rings gas injection system along cylinder walls.

Ensures quick and effective homogenous cooling turning the crystals in order to obtain a soft, creamy and stable gelato in the showcase.

▪ Mixer

The blades icebreaker mixer made by stainless steel, with interlocking connection in the front door to keep it aligned along time. Mixer prevents the formation of ice along cylinder's walls, keeping intact their cooling efficiency. It is equipped with self-adjusting scraper teeth that adhering perfectly to the cylinder walls to prevent the igloo effect, crush ice crystals and making them more fine.

▪ Front door

Front door made by special heat insulating material to prevent the dispersion of cold. It contributes to rapid batch freezing, reducing power consumption and avoiding dripping during gelato extraction. Lightweight easy to disassemble, clean and reassemble.

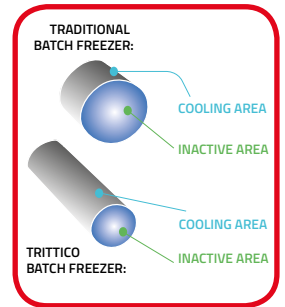

TECHNICAL FEATURES

- Upper tank to quick charging of the mixture
- Upper funnel on front door to charging flavors and other ingredients.
- Fast gelato extraction system.

ADVANTAGES

- Easy charging of the mixture.
- Easy use of the machine.
- Electronical control of work cycles
- Reduced consumption (**Bravo** patented condenser).
- Maximum convenience and easy to clean.

** Patented device that, thanks to the inverter, allows the software to change independently the blender's rotating speed.*

OPTIONALS

About any information about available OPTIONAL for Gelmatic please look at the brochure in the attachment.

MULTI-MACHINE SYSTEM

IT REQUIRES 3 DIFFERENT PRODUCTION STEPS:

1. PASTEURIZATION

Pasteurization is the heat treatment of gelato mixture and has two functions: first, it reduces the bacterial load of the mixture to ensure the best hygiene. Then -through a proper warming phase- it makes the solid components of the mixture (such as sugars) melting and becoming soluble. The whole process is done preserving as much as possible the nutritional value and organoleptic quality of each ingredient.

This process, which take its name from Louis Pasteur, provides a heating of the fluid food at temperatures below 100°C and then a quick and continuous cooling to reach 4°C. As far as the gelato production concerns, there are two pasteurization processes which are the most common: "high temperature" during which the heating process achieves 85°C and "low temperature" during which the mixture reaches 65°C and keeps this temperature for thirty minutes.



2. AGEING

Ageing is the preservation of the mixtures at 4°C while they are still under stirring for hydration for a time between 6 and 72 hours. This process requires very long times and considerable energy consumption. Moreover, to be efficient and to avoid the division and stratification of fat components, this method requires the mixture to be homogenized before starting the ageing process. And for this purpose it is necessary a further machine which is called homogenizer and which is used in the industrial production.



3. BATCH-FREEZING

Batch-freezing is the last and the most important step to get the finished product. The batch freezer has the important task of monitoring and managing the changes in status of the mixture.

The mixture is inserted in the cylinder of the batch freezer where the evaporators ensure the necessary cold supply to quickly make a liquid product (gelato mixture) becomes solid (gelato) by turning water into tiny ice crystals (thanks to the power of the mixer scrapers) in order to get a perfect structure of the final product.

The key is the quickness of the freezing process -to avoid stratification- and the perfect mixing of the fluid, which is made possible by the mixer. This tool, in particular, avoids the fluid deposit on the inner walls of the cylinder and ensures the best overrun (air incorporation) to get a good consistency at the time of extraction.



pastmatic®

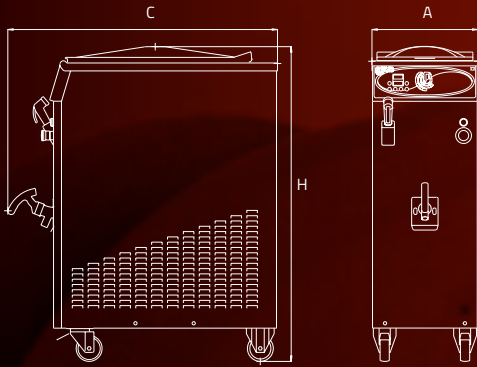

TECHNICAL SPECIFICATIONS		60		2x60	
Max. Mixture *1	Lt/cycle	30/60		30/120	
Voltage *2	Volt Hz/Ph	400/50/3		400/50/3	
Power	kW	4,6		9,2	
Refrigeration condenser *3		Water	Air+Water	Water	Air+Water
Width (A)	cm	40	40	80	80
Depth (B-C)	cm	102 (B)	122 (C)	102 (B)	102 (B)
Height (H)	cm	119	119	119	119
Weight *4	kg	151	---	255	---

*1 Hourly production may change accordingly to type of mixture and finished product density.
 *2 Available also in 60 Hz. *3 Water: cooled system self contained. Air+Water: incorporated water condenser and remote air cooled condenser. *4 The weight of the air cooled machines will be estimated before the shipment.

tinox

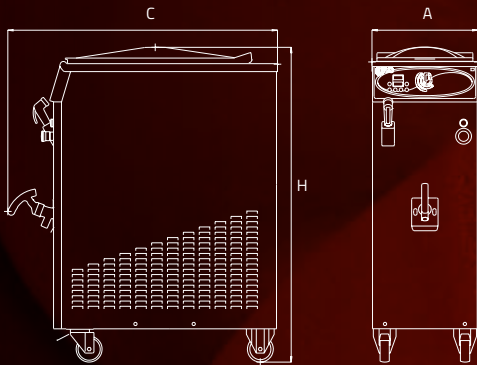

TECHNICAL SPECIFICATIONS		60		2x60	
Max. Mixture *1	Lt/cycle	30/60		30/120	
Voltage *2	Volt Hz/Ph	400/50/3		400/50/3	
Power	kW	2,5		5	
Refrigeration condenser *3		Water	Air+Water	Water	Air+Water
Width (A)	cm	40	40	80	80
Depth (B-C)	cm	102 (B)	122 (C)	102 (B)	102 (B)
Height (H)	cm	119	119	119	119
Weight *4	kg	149	---	252	---

*1 Hourly production may change according to type of mixture and finished product density. *2 Also available in 60 Hz. *3 Water: cooled system self contained. Air+Water: incorporated water condenser and remote air cooled condenser. *4 The weight of the air cooled machines will be estimated before the shipment.

gelmatic®

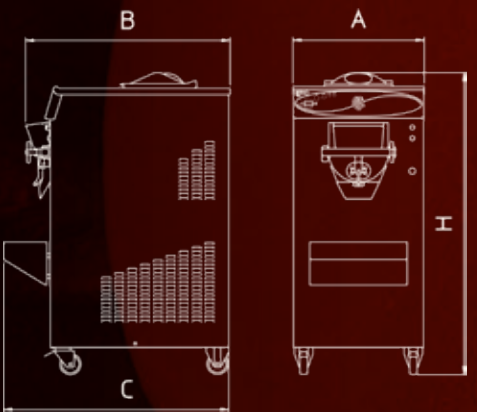

TECHNICAL SPECIFICATIONS		305		457		610		1015		1020	
Prod. for cycle		5		8,3		10		15		20	
Average hourly production *1	Lt/ciclo	25/38		37/56		50/75		75/110		90/135	
Voltage *2	Volt/Hz/Ph	400/50/3		400/50/3		400/50/3		400/50/3		400/50/3	
Power	kW	2,8	2,9	4,4	4,6	5,6	6	7	7,3	13,5	13,8
Refrigeration condenser		Water	■ Air + Water	Water	■ Air + Water	Water	▲ Air + Water	Water	▲ Air + Water	Water	▲ Air + Water
Width (A)	cm	51	51	51	61	61	61	61	61	61	61
Depth (B)	cm	80	97	95	95	95	95	95	95	115	115
Depth (C)	cm	87,5	103,5	102,5	102,5	102,5	102,5	102,5	102,5	122,5	122,5
Height (H)	cm	140	140	140	140	140	140	140	140	140	140
Weight PREMIUM (3)	Kg	233	---	285	---	313	---	359	---	472	---
Weight PLUS (3)	Kg	226	---	279	---	303	---	349	---	452	---

*1 Hourly production may change according to type of mixture and finished product density.
 *2 Also available in 60 Hz. (3) Weight of the basic machine. The weight of the air cooling machines will be estimated before the shipment.
 ■ Air+Water: incorporated cooling condenser. ▲Air+Water: incorporated water condenser and remote air cooling condenser.



HEADQUARTERS Bravo S.p.A.
 Montecchio Maggiore - Vicenza, Italy
 Ph.: +39 0444 707700
 Email : info@bravo.it

www.bravo.it

Bravo France
bravofrance.fr
info@bravofrance.fr

Bravo Asia
bravo.asia
info@bravo.asia

Bravo North America
bravonorthamerica.com
info@bravonorthamerica.com

Bravo Deutschland
 Ph.: +49 160 1007072
info@bravodeutschland.de

Bravo Middle East
 Ph.: +971 559 896516
Info@Bravomiddleeast.com